

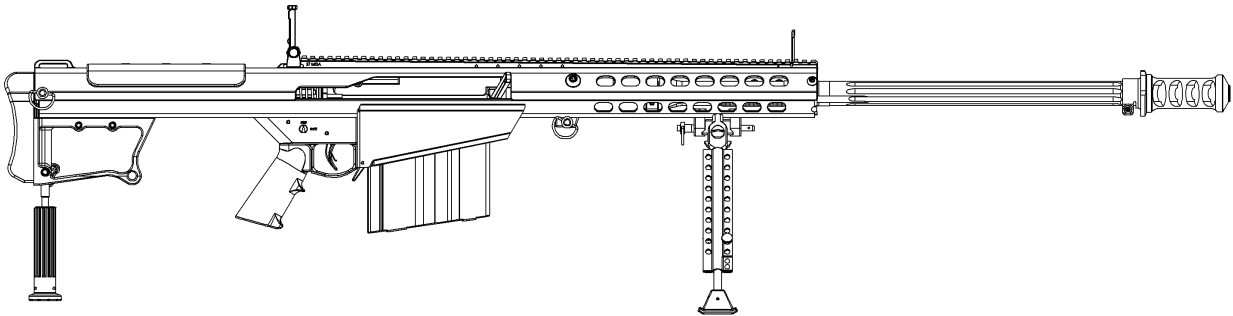

M107A1



Operator's Manual

PO Box 1077 Murfreesboro, TN 37133 / 615.896.2938 / 615.896.7313 / mail@barrett.net

USE OF THIS MANUAL

Before you handle the M107A1 rifle, read this manual in its entirety. It is important that you understand the principles of safe gun handling in general and the unique features of this rifle. This manual is not a substitute for training from a qualified instructor.

Important safety topics are discussed in this chapter and throughout this manual. This manual should remain with the rifle and it should be transferred with the rifle to subsequent owners. Additional manuals can be ordered from Barrett Firearms Manufacturing, Inc. or can be downloaded from the company website, barrett.net.

This manual covers all variants and calibers of the M107A1 and M107A1 CQ. Technical specifications are subject to change without notice.

SAFETY GUIDELINES

WARNING

Failure to follow safety guidelines may result in injury or death.

Ammunition

Barrett does not condone the use of hand loaded, remanufactured, or surplus ammunition. The use of clean, dry and properly stored commercially manufactured ammunition will preserve your warranty.

Safety distance

Bullets fired from this rifle may travel as far as 5 miles. Make certain that you have an adequate backstop.

Hearing protection

Hearing loss is permanent. Hearing loss from gunfire is cumulative, but the noise from even one shot may cause permanent loss. Even when firing suppressed, Barrett recommends that you wear both earplugs and earmuffs. It is also your responsibility to protect the hearing of those around you. The muzzle brake is integral to the design of your rifle and works to divert a large portion of a shot's blast rearward and to the side of the muzzle. Your rifle must not be fired without it. People and objects should not be in the vicinity of the muzzle brake because its blast consists of high pressure and high temperature gas. All spectators should use double hearing protection. The safest place for a spectator is directly behind the shooter.

Eye protection

Eye protection should be worn when both shooting and maintaining your rifle. It is normal for firing to generate airborne dust and debris. Glasses also protect you from scopes during recoil. Protect your eyes from solvents and uncaptured parts under spring pressure while performing maintenance on your rifle.

Assume every gun is loaded

Treat every gun as if it were loaded. Do not trust your memory and do not take anyone else's word for it. Visually look and physically feel for an empty chamber. Do not trust the extractor to provide an empty chamber.

Beware of barrel obstructions

Ensure the barrel's bore is free of obstructions before you fire your rifle. Even the smallest obstruction such as a stuck patch or even grease will cause dangerously increased pressures that can rupture the barrel.

Use your muzzle brake

Your rifle was designed to be fired with the muzzle brake installed. Firing your rifle without the muzzle brake will subject your rifle and its accessories to damaging recoil. It could also cause the shooter to be injured.

Muzzle control

Always keep the muzzle pointed in a safe direction. Never allow your muzzle to point at anything that you do not intend to shoot.

Keep your finger off the trigger

Keep your finger off the trigger and out of the trigger guard until your sights are aligned on your target and you intend to fire.

Keep your safety on

Keep your safety on until your sights are aligned on your target and you intend to fire.

Identify your target and backstop

Before you pull the trigger, make certain of your target and what is beyond it. The rifle should never be fired at surfaces where bullets are likely to glance off in unpredictable directions.

Failure to fire

If your rifle fails to fire when you pull the trigger, do not attempt to clear the action. Keep the rifle pointed toward a safe area and wait two minutes. If a hang fire (slow ignition) has occurred, the round will probably fire within two minutes. If the round does not fire, remove and inspect the cartridge. If the primer is indented properly, discard it in a safe manner. If the primer is lightly dented, refer to the troubleshooting chart in this manual.

Maintain your rifle properly

Performing proper maintenance, as outlined in this manual, insures that your rifle will be safe to shoot and will perform to design specification for many years. Alterations, modifications or adjustments may damage your rifle, make it unsafe to fire and will void warranty claims.

Store your rifle safely

Even though your rifle represents a significant financial investment, the greatest value in keeping it secured is preventing it from falling into the hands of a child, a careless adult, or a thief. It is your responsibility to take every reasonable precaution to secure your rifle.

Alcohol, medications and drugs

Do not handle or operate your rifle under the influence of alcohol, medication or drugs.

WARRANTY AND SERVICE

Barrett Firearms Manufacturing, Inc. (BFMI), warrants that this firearm was manufactured free of defects in materials and workmanship. For one year from the date of purchase by the original owner, BFMI agrees to correct any defect in this firearm for the original purchaser by repair or replacement with the same or comparable model.

BFMI will not be responsible for injury, death, or damage to property resulting from either intentional or accidental discharge of this firearm or from its function when used for purposes or subjected to treatment for which it was not designed. BFMI will not honor claims involving this firearm which result from careless or improper handling, unauthorized adjustment or parts replacement, corrosion, neglect, the use of the wrong caliber ammunition, or the use of other than commercially manufactured ammunition in good condition, or any combination thereof. BFMI will not honor claims involving this firearm when such claims are made by the second or subsequent owner.

If you need factory service, whether made under warranty or not, please contact BFMI for a Return Authorization Number and instructions on how to have your gun repaired.

Barrett Firearms Manufacturing Inc.
P.O. Box 1077
Murfreesboro, TN 37133-1077
615-896-2938
mail@barrett.net

www.barrett.net

LIMITATION OF LIABILITY

The liability of Barrett Firearms Manufacturing, Inc. for any and all losses and damages to the purchase shall in no event exceed the purchase price of the firearm, and then only if the firearm is proven to be defective in material or workmanship. Barrett Firearms Manufacturing, Inc. shall under no circumstances be liable for incidental or consequential damages resulting from negligence of Barrett Firearms Manufacturing Inc. or from negligence or misuse of the purchaser.

Barrett Firearms Manufacturing, Inc. makes no other warranties of any kind, expressed or implied with respect to the M107A1.

Your Responsibility

Your Barrett rifle is well-engineered and manufactured to the highest standards. It was proof-fired and carefully inspected before it was packaged and shipped from our factory. Its safe use depends on you alone. You are the ultimate safety device. Much like other mechanical devices, such as electric power tools, gas-powered lawn equipment, and automobiles, your rifle is safe unless handled in an irresponsible or uneducated manner.

TABLE OF CONTENTS

Use of the Manual	1
Safety Guidelines	1-3
Warranty and Service	4
Table of Contents	5
Specifications & Capabilities	6
Contents	7
General Function, Storage, Repair	8
Break-in	8
Equipment Description & Data	9-10
Inspection of Major Components	11
Upper Receiver	12
Bolt Carrier Group	13
Lower Receiver	14
Assembly of Major Components	15-19
Operating the Rifle	20-23
Suppressor	24-25
Preventative Maintenance Procedures	26
Cleaning and Lubrication	27
Exploded Views and Parts Lists	28-29
Troubleshooting	30-32

SPECIFICATIONS

Model:	M107A1	M107A1 CQ
Caliber:	.50 BMG (12.7 x 99 mm)	.50 BMG (12.7 x 99 mm)
Operation:	Semi-Automatic	Semi-Automatic
Weight:	28.55 lbs (12.95 kg)	27.25 lbs (12.36 kg)
Overall Length: (Assembled)	56.8" (144.28 cm)	48.4" (122.94 cm)
Length: (Takedown Mode)	37.75" Lower 41.375" Upper	37.75" Lower 41.375" Upper
Barrel Length:	29" (73.66 cm)	20.6" (52.32 cm)
Barrel Twist:	1:15	1:15
Magazine Capacity:	10 rounds	10 rounds
Stock:	Integral with Lower receiver – steel	Integral with Lower receiver – steel
Safety:	Manual thumb-lever	Manual thumb-lever
Sights:	Fixed front, Adjustable rear sights	Fixed front, Adjustable rear sights

CAPABILITIES

Muzzle Velocity: M107A1 .50 BMG—Approximately 2750 f/s (853 m/s) with standard 660 grains (42.8 g) projectile

M107A1 CQ .50 BMG – Approximately 2500 f/s (762 m/s) with standard 660 grains (42.8 g) projectile

Maximum Range: Approximately 8,046 meters

CONTENTS

Your M107A1 rifle includes the following:

- Rifle
- Watertight and airtight carrying case
- Operator's manual
- 1 Magazine

Your rifle may have included a monopod, bipod, suppressor, rifle scope, BORS, rings or other optional accessories. It may have also included cleaning fluids and a cleaning kit.

The rifle is shipped from the factory in 2 pieces; the upper receiver assembly and lower receiver assembly.

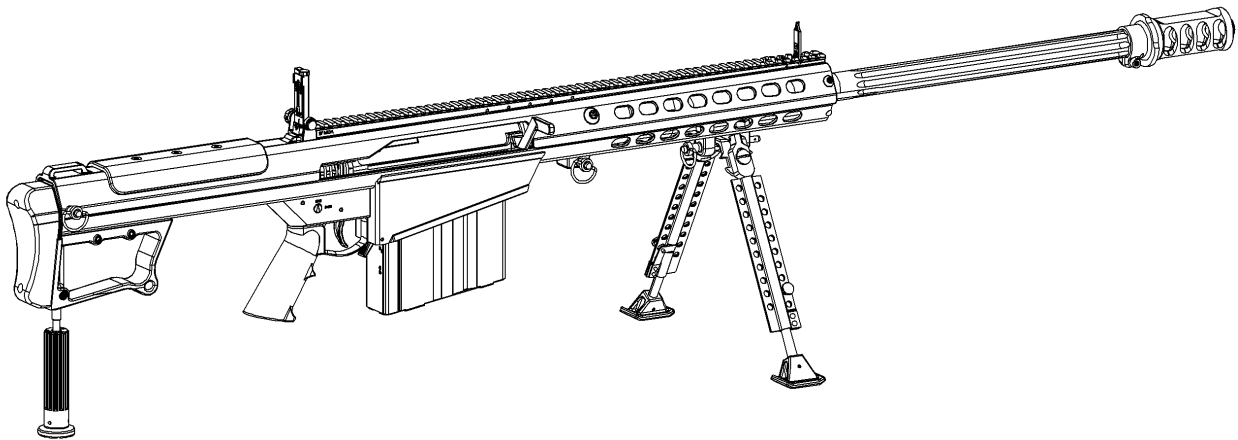

TYPE OF MANUAL: Operator's instruction manual for the Barrett M107A1 rifle.

GENERAL FUNCTION

As the cartridge is fired, the energy from the projectile drives the barrel rearward. The rearward moving barrel drives the bolt carrier rearward. As the bolt carrier moves to the rear, the bolt unlocks and the cartridge is extracted and ejected from the rifle. Near the end of the bolt carrier's rearward motion, the bolt is fully extended, the rifle is cocked and the main spring buffer is compressed. As the bolt carrier starts its forward motion, it feeds a new cartridge into the chamber and locks into battery position ready to fire again.

PREPARATION FOR STORAGE OR SHIPMENT

The M107A1 should always be stored and transported in its airtight, watertight carrying case where possible.

RIFLE REPAIR

Rifle repair will be accomplished by Barrett Firearms Manufacturing, Inc. In the event the M107A1 requires repair, it is to be sent as a complete assembly, packaged as described above.

BREAK-IN PROCEDURE

Because individual barrels, powder, primer and bullet combinations vary widely and because shooters have strongly held personal opinions on the subject, Barrett does not offer a specific procedure for barrel break-in. Barrett recommends that you do not overheat your barrel, especially your new barrel. Experience has shown that the bore becomes less prone to fouling over time and that accuracy may increase as this occurs.

EQUIPMENT DESCRIPTION AND DATA

Equipment Specifications and Capabilities. The technical specifications and capabilities of the M107A1 (Figure 1-1).

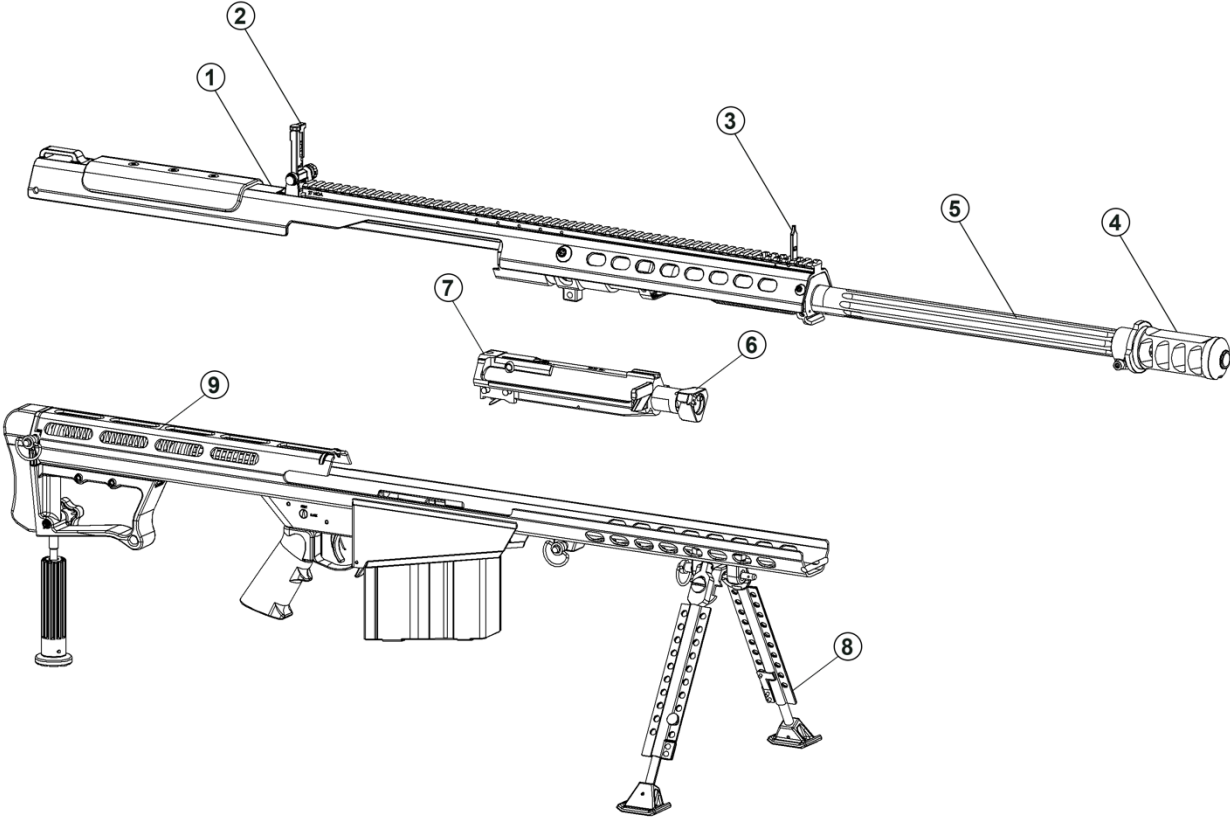

Figure 1-1. Rifle, M107A1

IDENTIFICATION AND DESCRIPTION OF MAJOR COMPONENTS

1. **Upper Receiver.** Aluminum extrusion cover combining and including the front and rear sights, integrated scope rail, cheek piece, muzzle brake and barrel.
2. **Rear Sight Leaf.** Peep style aperture with elevation markings for 100 to 1500 meters. Rear sight scale for .50 BMG.
3. **Front Sight.** Flip up from inside the rail.

4. **Muzzle Brake.** Critical for recoil absorption. Cylindrical design for Sound Suppressor integration.
5. **Barrel.** Muzzle end is threaded to accept cylindrical muzzle brake; breech end has a barrel extension integral to the locking function.
6. **Bolt.** Lightweight and Nickel Teflon coated. Houses the extractor and ejector.
7. **Bolt Carrier.** Consists of the bolt (8), firing mechanisms, cocking lever, and sear.
8. **Bipod Assembly.** Forward support system comprised of lightweight Titanium retractable bipod legs and Polymer extending feet. Bipod assembly is quick-detachable from the receiver.
9. **Lower Receiver.** Sheet metal cover combining and including the bipod assembly, buffer, midlock pin, and trigger mechanism.

INSPECTION OF MAJOR COMPONENTS

WARNING

Unload and clear the rifle before disassembly.
Ensure no live ammunition is present during disassembly or assembly.

Inspection of Rifle's Major Components

The rifle's four major groups are packaged as shown in below.

1. Upper Receiver
2. Bolt Carrier Group
3. Lower Receiver

Ensure all components are present and inspect for obvious damage, reporting any discrepancies to the Barrett factory. Detailed inspection should be conducted as follows:

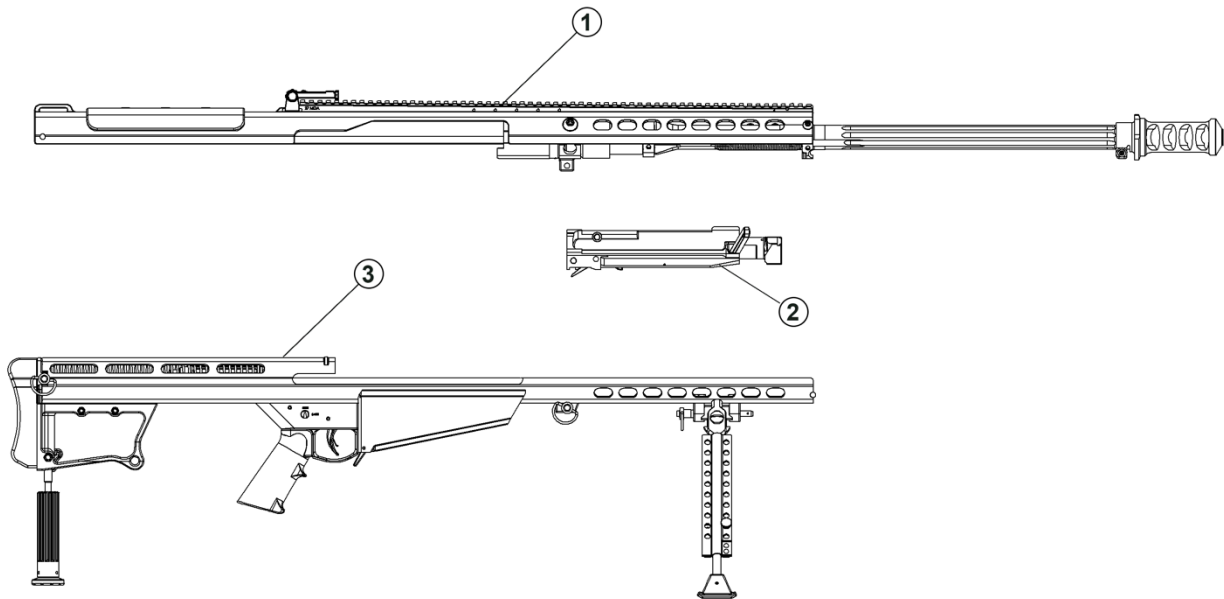

INSPECTION - THE UPPER RECEIVER

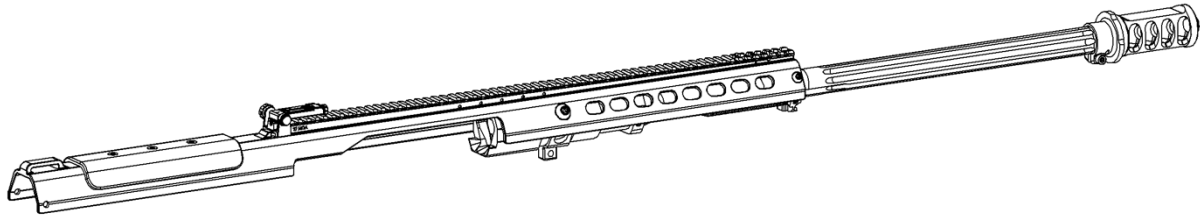

1. Barrel springs must not be overstretched, and each coil should be tight, with no spaces between coils.
2. Battery bumpers should be in good condition (not frayed, cracked, or twisted).
3. The muzzle brake should be tight and fully screwed on.
4. The upper receiver should not be cracked, bent, or burred.
5. Check the hinge lip at the front of the upper receiver to ensure that it is not cracked, bent, or deformed in any way.
6. The barrel should be clean and free of obstruction.
7. All scope mountings should be tight, in good condition, and free of oil (iron sights, front and rear, may be lightly oiled at pivot points to prevent corrosion).

INSPECTION - THE BOLT CARRIER GROUP

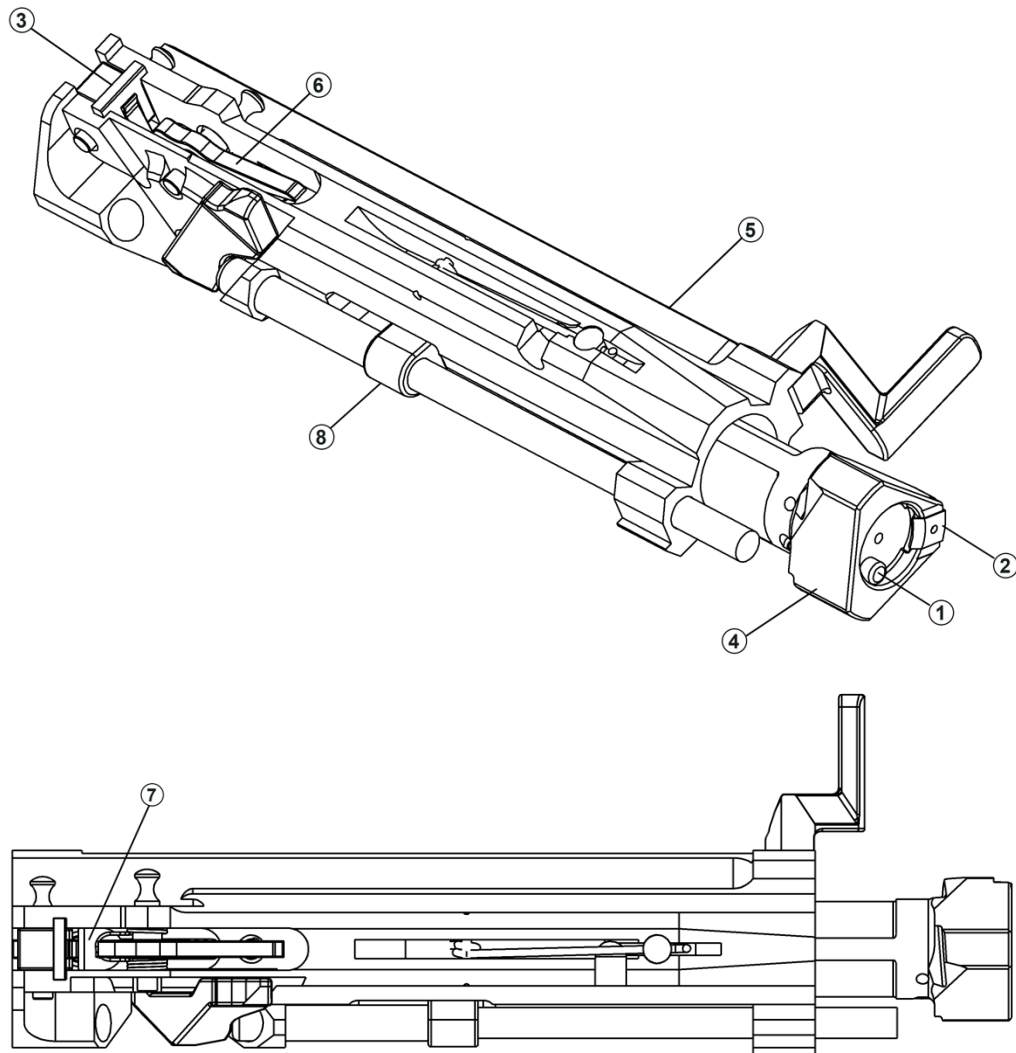

1. Ejector (1) and extractor (2) must be checked to ensure they are under spring tension, and neither chipped nor worn. Extractor and Ejector should not stick in one position.
2. With firing mechanism de-cocked (use rear lock pin to depress sear (3)), manually work the bolt (4) in and out, feeling for any roughness, which may indicate wear, corrosion, or dirt/grit in the bolt carrier (5).
3. Push the bolt into the carrier and inspect the firing pin to ensure it is protruding the bolt face. Check firing-pin hole (on bolt face) to ensure it is not eroded or elongated. Bolt face should not be pitted.
4. Swing the cocking lever (6) forward. The sear (3) should capture the firing-pin extension (7) before the cocking lever is fully depressed.
5. Manual Bolt Extender (8) slot should be free and clear of debris

INSPECTION - THE LOWER RECEIVER

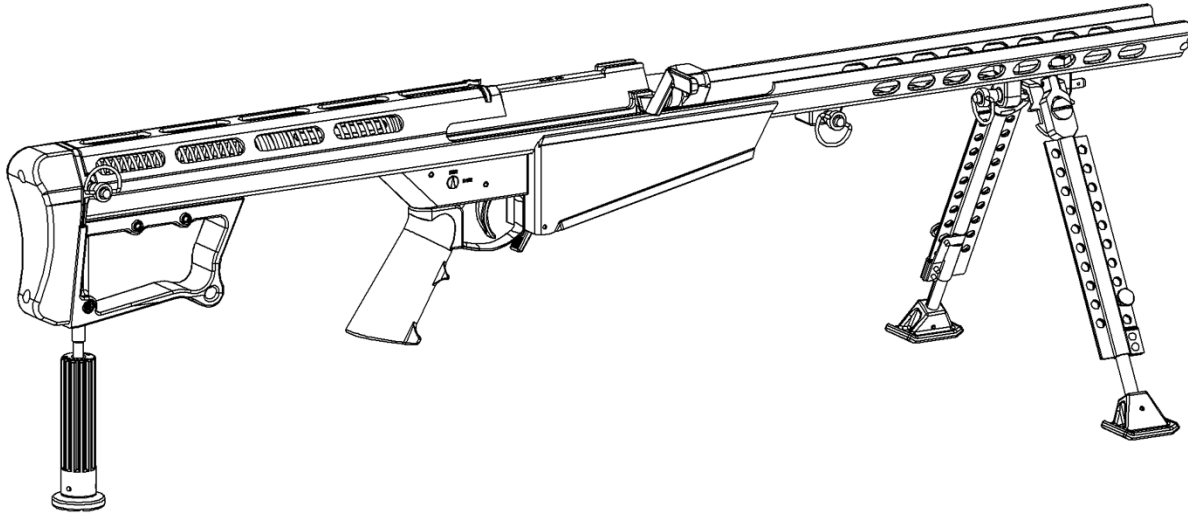

1. With bolt carrier in place, pull it rearward and check to see that the mainspring moves freely (full travel) and is not deformed.
2. Hold bolt carrier back while clearing the mainspring housing (sheet metal closure). With the thumb safety on fire, pull the trigger. Firing mechanism should function (a slight rise in bolt carrier is normal). If the housing is bent, the bolt carrier will rise excessively as the trigger is pulled, preventing proper functioning.
3. Lower receiver should not be cracked, bent, or burred.
4. Check the hinge pin at the front of the lower receiver to ensure that it is not cracked, bent, or deformed in any way.
5. Check bipod assembly for function and ensure the mounting hardware is tight.

ASSEMBLY OF MAJOR COMPONENTS

1. Grasp the Lower Receiver Group and extend the bipod legs by pulling the legs down to the front, where they will lock into place. To retract, pull down on leg and swing back into position along the receiver. If firing without using the bipod, fold them forward to preclude interference with the charging handle. Pulling on the feet of the bipod causes the legs to extend. To retract a leg, depress the plunger located on the bipod leg and push up on the foot. Place receiver on level surface.

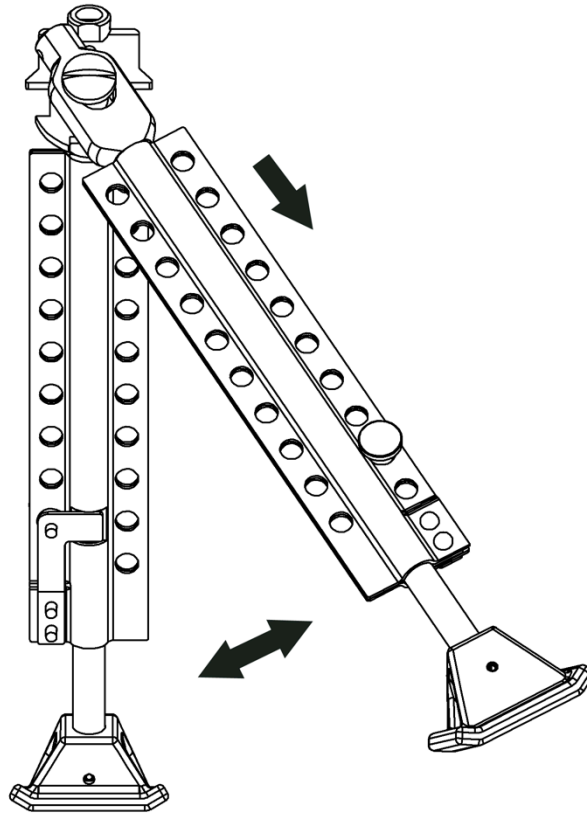

2. The Bolt Carrier Group is held in place under tension in the lower receiver by the midlock pin, which extends through a locking hole in the receiver's sheet metal. (Both the midlock pin and the rear lock pin, located in a retaining hole in the end of the buttstock, have finger rings to aid in removal.)

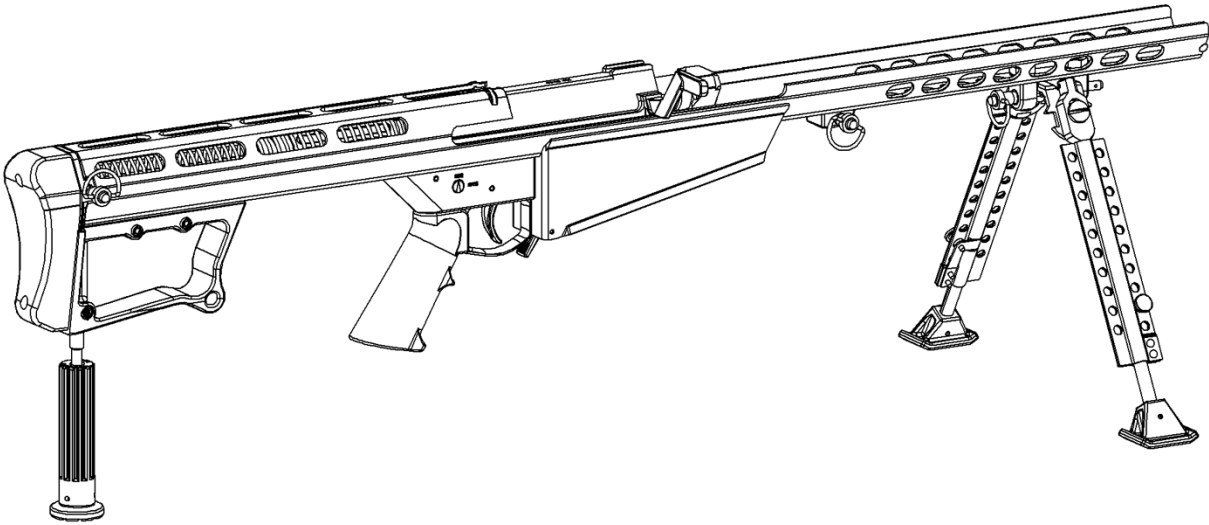

3. Standing above and to the rear of the lower receiver, grasp the charging handle with the right hand, and carefully pull back, against tension, while withdrawing the midlock pin from its retaining hole. Allow the bolt carrier to come forward **SLOWLY** until there is no more spring tension and it rests in the lower receiver.

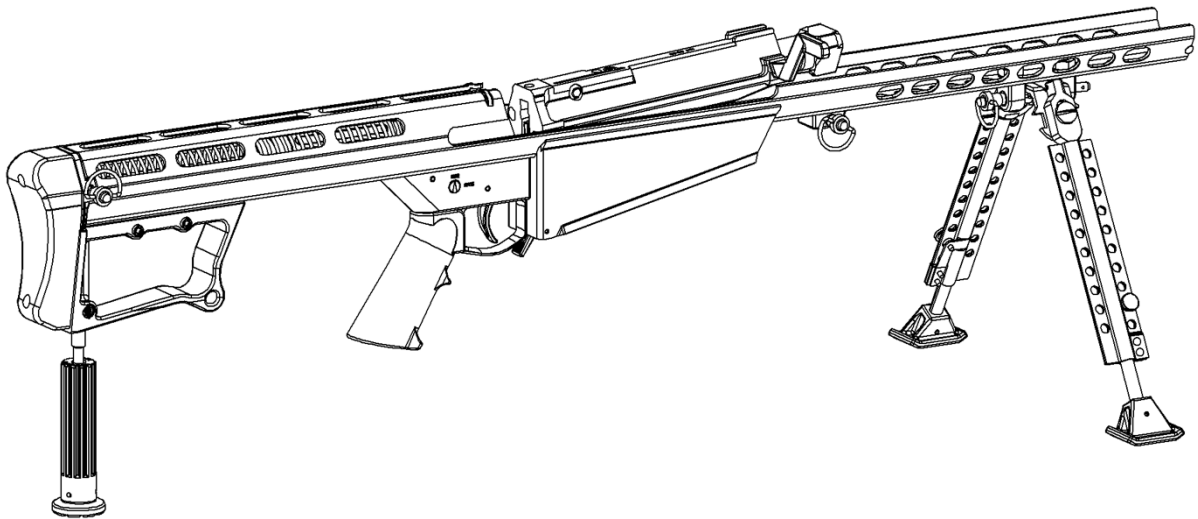

4. Carefully pick up the upper receiver. The barrel will be nested inside for compact storage. Align the barrel so that its feed-ramp (slanted entry to firing chamber) is to the bottom. Keeping fingers away from the barrel hold the upper receiver horizontally in the direction of the muzzle. The barrel should fall into place at its full forward extension in the receiver. Slide the impact bumper into position on the large diameter of the barrel and against the barrel stop.

WARNING

THE TENSION ON THE BARREL SPRINGS IS ABOUT 70 lbs (32 kg). SERIOUS INJURY COULD RESULT IF SPRINGS ARE SUDDENLY RELEASED.

5. The barrel springs at the front of the upper receiver are held together by the barrel key. Maintaining the downward tilt of the upper receiver (to keep the barrel in place) firmly grasp the barrel key—not the springs—and pull it into place on the forward slot of the barrel. Work the barrel key until it is firmly seated in the barrel slot. The upper receiver is now fully assembled.

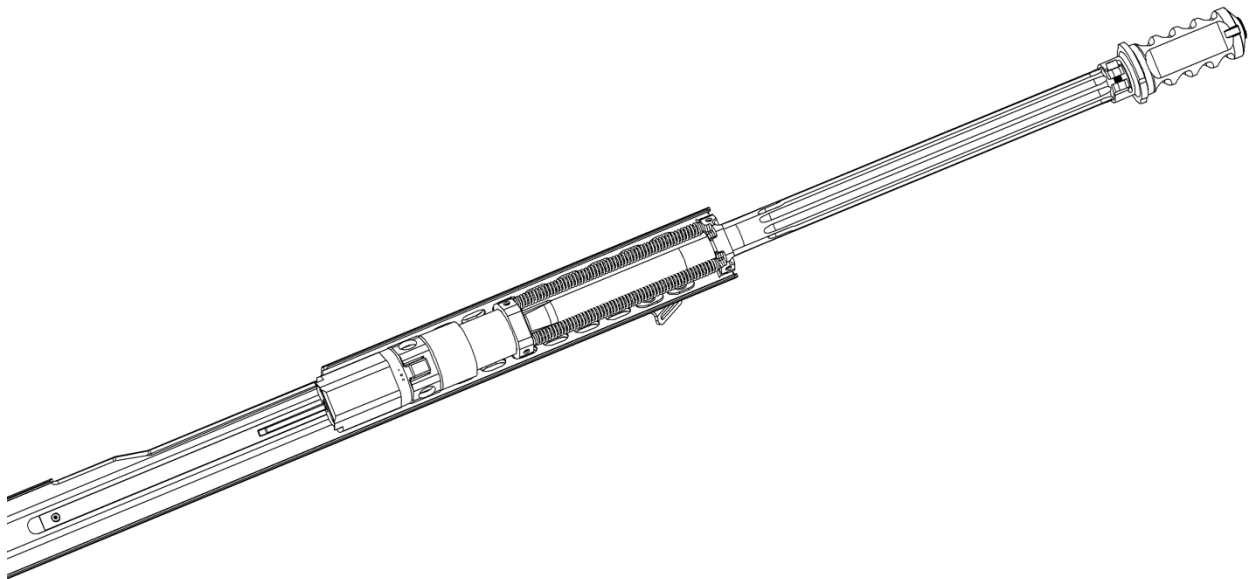

6. Position the upper receiver rear up, muzzle down, over the lower receiver.

CAUTION

BE SURE THE UPPER RECEIVER NOTCH AND LOWER RECEIVER HINGE PIN ARE PROPERLY MATED, OR THE RIFLE CAN BE DAMAGED BY FINAL ASSEMBLY MOTION.

- Engage the notch in the front barrel bushing of the upper receiver with the front hinge pin of the lower receiver. While positioned directly behind the rifle, grasp the charging handle and pull rearward against mainspring tension so the bolt will clear the barrel extension when the upper receiver is lowered.

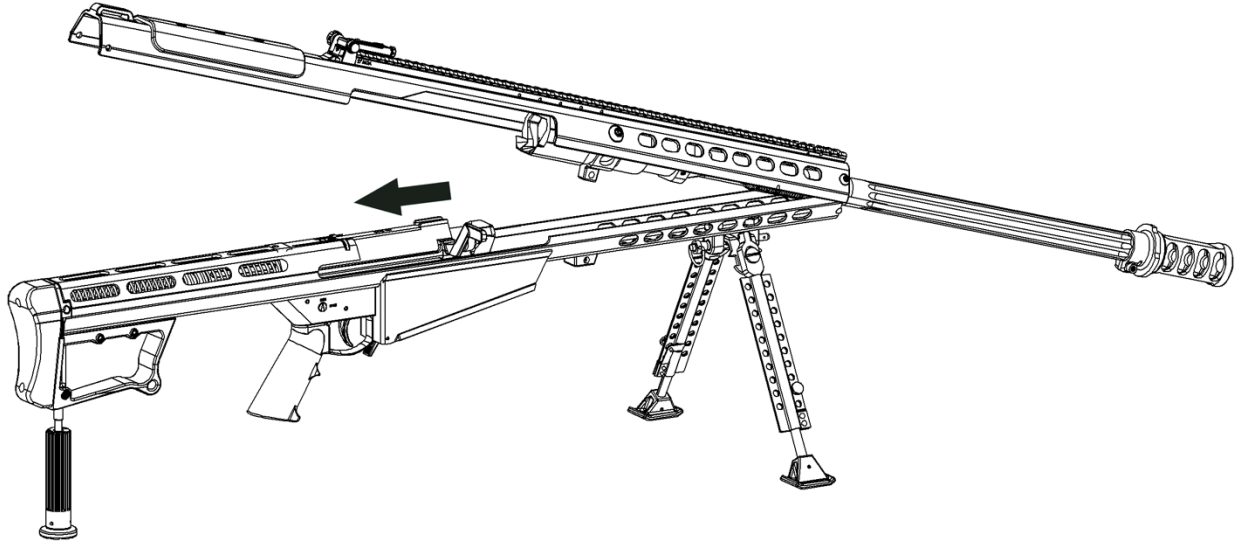

- Lower and close the upper receiver onto the lower receiver. Release the charging handle **SLOWLY** until the bolt is fully closed.

WARNING

THE RIFLE MUST NOT BE FIRED WITHOUT BOTH THE MIDLOCK AND REAR LOCK PINS FIRMLY IN PLACE. SERIOUS INJURY OR DEATH COULD RESULT.

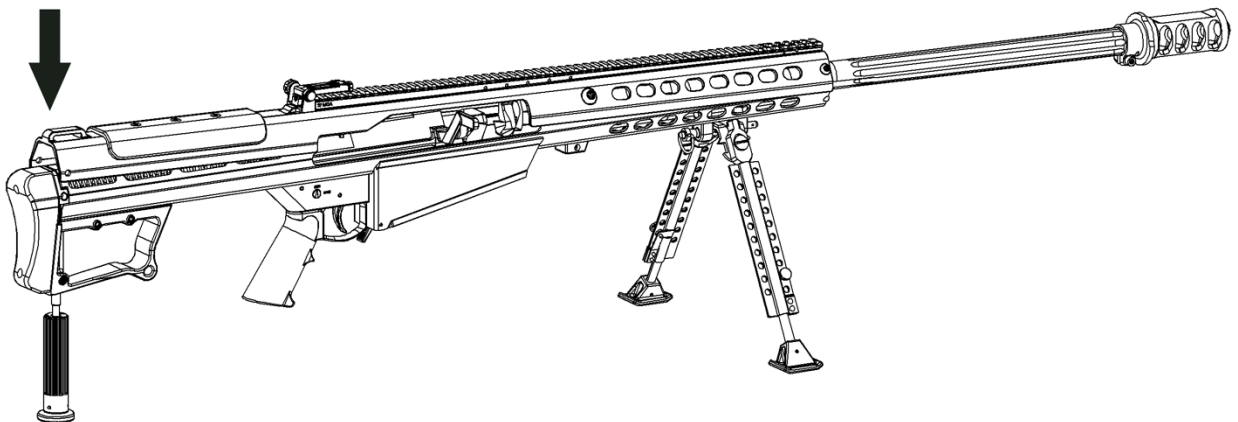

9. Place the midlock pin (shorter pin) through the hole near center bottom of the rifle, until it snaps fully to lock the upper and lower receivers together. Insert the rear lock pin through the rear hole of the upper receiver to complete the mating of the receivers.

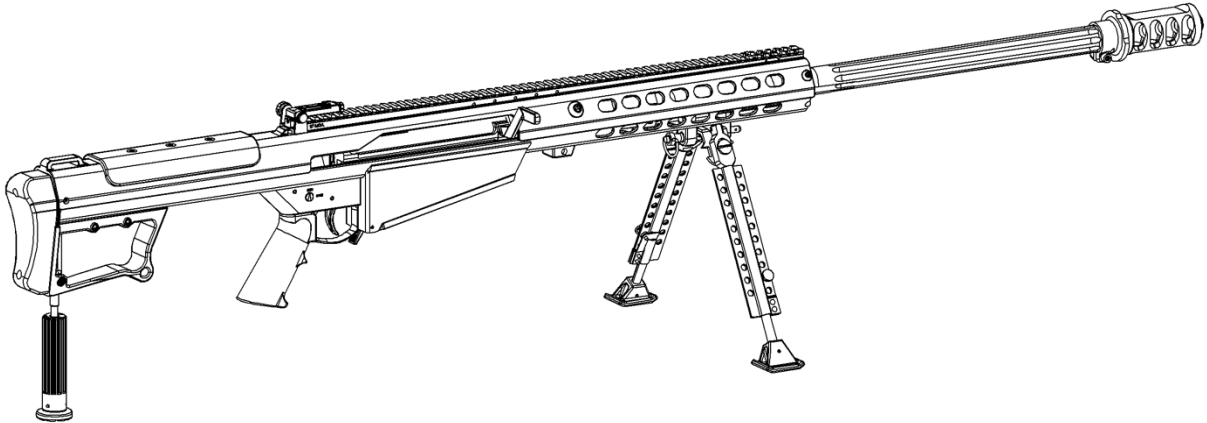

Inspection of the Action

WARNING

THERE SHOULD BE NO AMMUNITION PRESENT DURING THIS TEST.

1. Grasp the charging handle and dry-cycle the rifle several times (work the bolt all the way back and forth). This will serve two purposes. First, if there has been any damage to the sheet metal housing during shipping, the bolt carrier will not move freely. Second, the shooter will be able to determine if the bolt fully closes and rotates to a locked position.

OPERATING THE RIFLE

Loading the Magazine

Using appropriate ammunition, load the magazine in the normal manner. Ensure that cartridges are pushed all the way to the rear of the magazine. Load no more than 10 rounds.

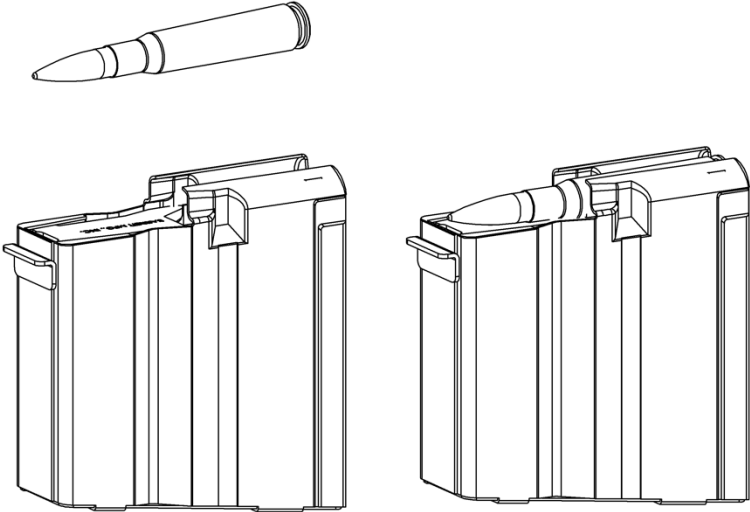

Safety

There is a single thumb-lever that prohibits the trigger from being pulled. Position the lever pointed towards SAFE.

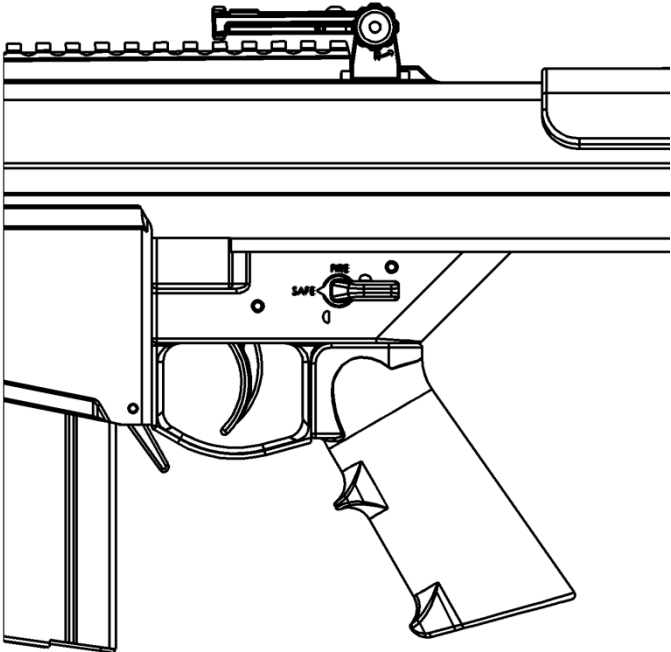

Inserting Magazine

1. Insert the magazine into the magazine well in the lower receiver, with magazine tilted at approximately a 45° angle (bullet tips upward). Insert the front of the magazine hook to its hinge, located in the front of the magazine well.

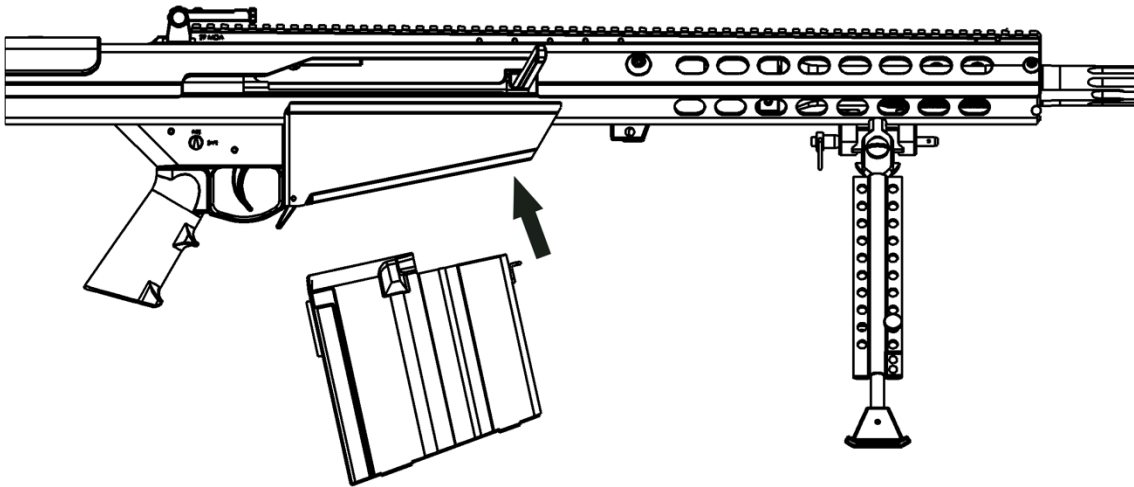

2. Swing the rear of the magazine up until it locks into place by means of the magazine catch. It should lock in with an audible click. Be aware that it is possible to insert the hook on the front of the magazine incorrectly. Pull down on the magazine to verify that it is properly seated.

Charging the Rifle

WARNING
DO NOT ATTEMPT TO FORCE A CARTRIDGE INTO THE CHAMBER BY FORCING THE BOLT CLOSED. IF THE BOLT WILL NOT CLOSE EASILY, REMOVE THE CARTRIDGE AND EXAMINE IT FOR DAMAGE OR DEFECTS. CHECK THE CHAMBER FOR OBSTRUCTIONS.

1. With the safety in the safe position (safety lever horizontal) and the muzzle pointed in safe direction pull the charging handle to the rear until it stops, then release it (do not keep your hand on the charging handle). The rifle then loads and locks under its own spring power for all subsequent rounds.

Firing the Rifle

WARNING

DOUBLE HEARING PROTECTION SHOULD BE WORN WHEN FIRING SINCE HARMFUL LEVELS OF NOISE ARE GENERATED.

WARNING

THE SHOOTER MUST BE POSITIONED DIRECTLY BEHIND THE RIFLE WITH THE RECOIL PAD HELD FIRMLY AGAINST THE SHOULDER. FIRING THE RIFLE IN ANY OTHER POSITION COULD RESULT IN INJURY BY CONTACT WITH THE RIFLE OR RIFLE SCOPE.

1. Because the rifle is recoil-operated, the shooter must be positioned squarely behind the rifle, with the recoil pad firmly against the shoulder. Anything less may result in injury, discomfort, or failure of the action to cycle correctly.
2. Position the safety (lever vertical) pointed towards FIRE.

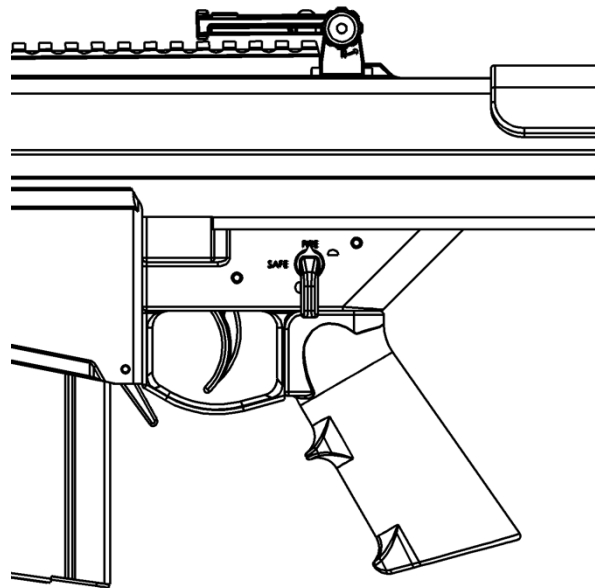

3. The rifle may now be fired. The rifle will fire one round for each squeeze of the trigger until the magazine and chamber are empty.

WARNING

THE BOLT DOES NOT AUTOMATICALLY REMAIN TO THE REAR WHEN THE RIFLE OR MAGAZINE IS EMPTY WHICH CAN CAUSE INJURY OR DEATH FROM AN UNINTENTIONAL DISCHARGE.

4. After the magazine is emptied, or you are done firing, use the selector to place rifle in “SAFE” position and remove magazine. Pull and hold the charging handle to the rear while visually and physically checking for an EMPTY chamber. Once you have ensured the chamber and magazine wells are empty, release the charging handle to allow the bolt to close.

Unloading Rifle

1. Place the rifle in the “SAFE” position (safety lever horizontal).
2. Press the magazine catch forward, towards the magazine and remove the magazine.
3. Pull the charging handle to the rear to eject any cartridge still chambered. (One method of indicating the rifle has been cleared is to take an empty cartridge case, insert it halfway into the ejection port so that the neck is visible, and ease the bolt forward onto it.)

CAUTION

DO NOT LEAVE ROUNDS IN THE MAGAZINE FOR EXTENDED PERIODS OF TIME SINCE THIS WILL CAUSE THE SPRING TO LOSE TENSION AND MAY CAUSE A MALFUNCTION.

Unloading the Magazine

1. Hold the magazine in either the right or left hand, cartridges facing away from you.
2. Using the thumb of the other hand, push the cartridges out one after another, until all are ejected.

SUPPRESSOR

Your Barrett M107A1 Rifle System may include a Barrett Sound Suppressor.

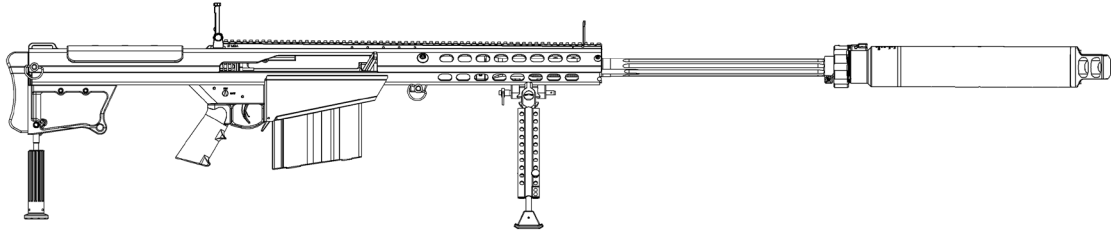

Auxiliary Muzzle Brake

The Barrett suppressor system comes with a detachable auxiliary muzzle brake. The suppressor functions with or without this brake, depending on your preference. The brake will alleviate some recoil, but the most sound and flash suppression is accomplished without the brake.

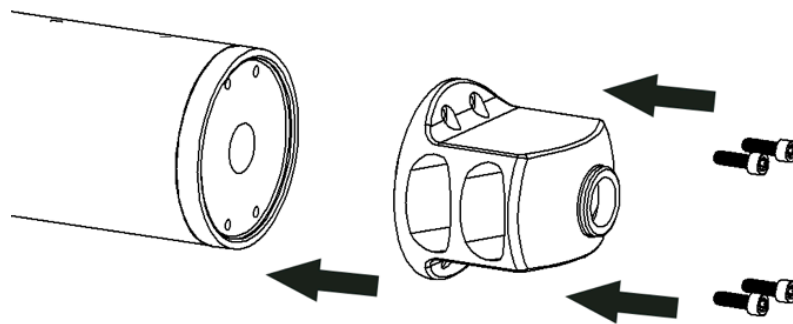

1. To install the auxiliary muzzle brake, you will need T-25 Torx Wrench.
2. Clean the face of the suppressor and place the auxiliary muzzle brake on the front, aligning the bores.
3. Install and torque the 4 T-25 Torx Screws to 20 in/lbs.

Suppressor Installation

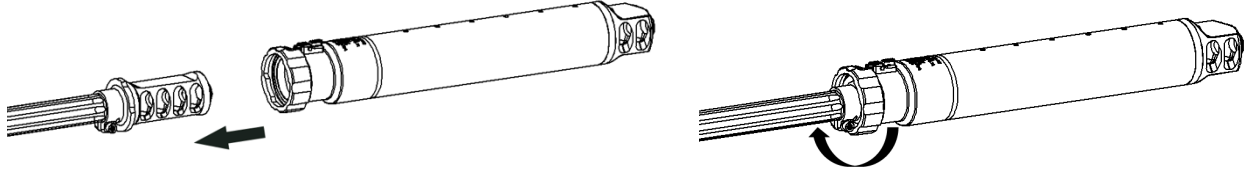

1. To install the suppressor, slide the coupling opening over the cylindrical muzzle brake, making sure the tabs clear the slots and the latch is in the “UNLOCK” position.
2. An indexing pin inside the suppressor locates on the rifle’s muzzle brake, ensuring proper alignment.
3. Tighten the suppressor lock ring by hand, engaging the notches with the latch and ensuring a secure fit. **NOTE: It is very important that this ring be tightly secured to keep the suppressor in place.**
4. To detach the suppressor, press the suppressor latch and turn the lock ring counter clockwise until notches are disengage and latch is in the “UNLOCK” position. Slide the suppressor off the rifle’s muzzle brake.

PREVENTIVE MAINTENANCE PROCEDURES

General Maintenance

1. Ensure that all bearing surfaces and exposed parts, particularly those listed below, are clean and lightly coated with a CLP (cleaner, lubricant, preservative) Oil.
 - a. Barrel
 - b. Bolt and bolt carrier
 - c. Mainspring housing
 - d. Trigger assembly
 - e. Transfer bar assembly
 - f. Lower Receiver

2. Inspect all parts for fit and tighten or replace, as necessary.
 - a. Inspect all parts (especially along welds) for cracks or damage and replace, if necessary.
 - b. Each time the rifle is assembled for firing ensure that the barrel, chamber, and locking lugs of the bolt are free of excess oil. When possible, an operational check using ten dummy rounds should be performed. Insert the dummy rounds into a magazine and load the magazine into the rifle. Manually cycle the bolt carrier group making sure the cartridges feed, extract, and eject properly.
 - c. Refer to the Troubleshooting section of this manual.

CLEANING AND LUBRICATION

WARNING
UNLOAD AND CLEAR THE RIFLE BEFORE CLEANING.

CAUTION
DO NOT INSERT CLEANING RODS THROUGH THE MUZZLE. THE BARREL CROWN COULD BE DAMAGED WHICH WOULD SEVERELY DEGRADE THE ACCURACY OF THE RIFLE.

CAUTION
TO PROTECT THE RIFLE FROM CORROSION, THE RIFLE AND THE INTERIOR OF THE CARRYING CASE SHOULD BE MOISTURE FREE BEFORE THE RIFLE IS PLACED IN THE CARRYING CASE FOR STORAGE.

Cleaning Procedure

1. The rifle should be cleaned and lubricated after each shooting session. Regular cleaning prevents the corrosive effects of moisture.
2. Apply cleaning solvent to a chamber brush and clean the chamber. Barrett Heavy Bore Cleaner is recommended.
3. Apply cleaning solvent to a bore brush and clean the bore. Barrett Heavy Bore Cleaner is recommended.
4. Clean the muzzle brake with a stiff plastic brush and bore solvent. It is best to clean the muzzle brake at the same time the barrel is being cleaned as the bore solvent will help loosen the carbon build-up on its interior walls.
5. Clean the bolt face with bore solvent. Use a stiff plastic brush to remove carbon from both the extractor and the ejector. Depress the ejector and extractor by hand to test their smooth function.
6. As soon as cleaning is finished, use dry patches as necessary to remove solvent from all cleaned surfaces.
7. Clean the remainder of the rifle with cotton-tipped swabs, general-purpose brushes and rags. Make sure all metal surfaces are coated with preservative oil.

M107A1 RIFLE

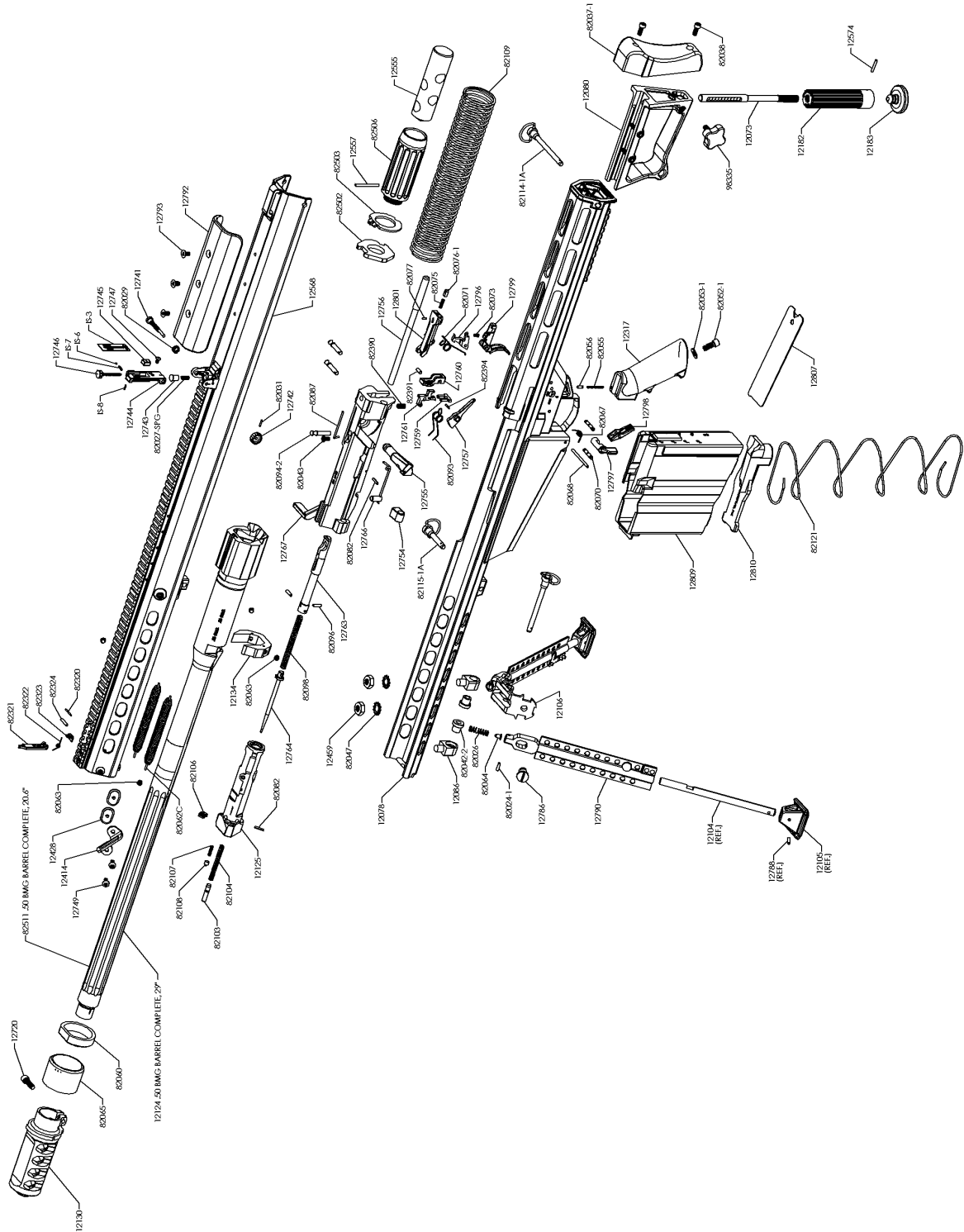

PART NO.	QTY.	DESCRIPTION
82029	1	SPRING (WINDAGE SCREW)
82031	1	RP - ϕ .062 x .375 LG.
12741	1	WINDAGE SCREW
12742	1	WINDAGE KNOB
IS-8	1	RP - ϕ .062 x .25 LG.
IS-7	1	SPRING (ELEVATION SCREW)
IS-6	1	BALL (ELEVATION SCREW)
12747	1	BHCS - 6-32 x .25 LG.
12746	1	ELEVATION SCREW
IS-3	1	REAR SIGHT SCALE
12744	1	REAR SIGHT BODY
12745	1	REAR SIGHT APERTURE
12792	1	CHEEK PIECE
12793	3	FHCS - 10-32 x .375 LG.
82322	1	FRONT SIGHT SPRING
82324	1	DP - ϕ .125 x .625 LG.
82320	1	RP - ϕ .062 x .625 LG.
82321	1	FRONT SIGHT
82323	1	FRONT SIGHT CATCH
12743	1	REAR SIGHT BASE DETENT
82027-SPG	1	REAR SIGHT BASE SPRING
12568	1	UPPER RECEIVER COMPLETE
12428	2	NUT PLATE
12414	2	FRONT SLING LOOP
12749	2	BHCS - 10-32 x .50 LG.
12130	1	TITANIUM MUZZLE BRAKE
12720	1	SHCS - 1/4-20 x .75 LG.
82060	1	BATTERY BUMPER
82065	1	IMPACT, BARREL BUMPER
12134	1	TITANIUM BARREL KEY
82063	4	SHSS - 1/4-28 x .187 LG.
12124	1	.50 BMG BARREL COMPLETE, 29"
82511	1	.50 BMG BARREL COMPLETE, 20.6"
82062C	2	BARREL SPRING COMPLETE
12768	1	LW BOLT ASSEMBLY
12766	1	CAM PIN ASSEMBLY
12763	1	FIRING PIN EXTENSION
82096	2	DP - ϕ .125 x .50 LG.
82098	1	FIRING PIN EXTENSION SPRING
12764	1	FIRING PIN
12767	1	BOLT CARRIER COMPLETE
12754	1	BOLT EXTENDER
82082	2	RP - ϕ .094 x .50 LG.
12755	1	ACCELERATOR
12756	1	ACCELERATOR ROD
12757	1	COCKING LEVER
12459	2	YOKE MOUNT NUT
82047	2	WASHER, YOKE MOUNT NUT
12799	1	TRIGGER
12796	1	DISCONNECTOR
12790	2	TITANIUM BIPOD LEG COMPLETE
12106	1	TITANIUM BIPOD YOKE
82026	2	BIPOD SPRING
82064	2	BIPOD DETENT
12786	2	BIPOD SCREW
12086	2	TITANIUM YOKE MOUNT
82024-1	2	BIPOD DETENT PIN
82042-2	2	BIPOD SHIM BUSHING
12078	1	LOWER RECEIVER COMPLETE (MACHINE)

PART NO.	QTY.	DESCRIPTION
82073	1	DISCONNECTOR SPRING
82071	1	TRIGGER SPRING
82391	1	DP - ϕ .156 x .375
82394	1	RP - ϕ .063 x .375 LG.
12759	1	SEAR LEVER
12761	1	SEAR
12760	1	SEAR HOUSING
12809	1	MAGAZINE COMPLETE
82121	1	MAGAZINE SPRING
12810	1	MAGAZINE FOLLOWER
12807	1	MAGAZINE FLOOR PLATE
82114-1A	2	PIN, REAR LOCK AND BIPOD
82115-1A	1	PIN, MIDLOCK
82109	1	MAIN SPRING
98335	1	MONOPOD LOCK KNOB
82053-1	1	GRIP SCREW WASHER
82052-1	1	SHCS - 1/4-20 x .625 LG.
12317	1	PISTOL GRIP
82070	2	TRIGGER HOUSING PIN
82067	1	MAGAZINE CATCH SPRING
82056	1	SAFETY DETENT
82055	1	SAFETY SPRING
82068	1	RP - ϕ .125 x 1.75 LG.
12797	1	SAFETY
12798	1	MAGAZINE CATCH
82038	2	SHCS - 10-32 x .375 LG.
82037-1	1	RECOIL PAD
82077	1	RP - ϕ .078 x .25 LG.
82075	1	TRANSFER BAR SPRING
82076-1	1	TRANSFER BAR DETENT
12801	1	TRANSFER BAR
12080	1	REAR GRIP COMPLETE
12183	1	MONOPOD LOWER
12182	1	MONOPOD UPPER
12073	1	TITANIUM MONOPOD ELEVATION SCREW
12574	1	RP - ϕ .125 x .75 LG.
12557	1	RP - ϕ .125 x 1.50 LG.
82503	1	BUFFER RETAINING RING
82502	1	BUFFER HEAD
12555	1	URETHANE INSERT
82506	1	BUFFER HOUSING
82094-2	3	BOLT CARRIER PIN
82093	1	COCKING LEVER SPRING
82043	1	FHCS - 8-32 x .375 LG.
82390	1	SEAR SPRING
82087	1	ACCELERATOR SPRING
12754	1	BOLT EXTENDER
82106	1	EXTRACTOR
82107	1	EXTRACTOR SPRING
82108	1	EXTRACTOR PLUNGER
82103	1	EJECTOR
82104	1	EJECTOR SPRING
82082	1	RP ϕ .094 x .50 LG.

TROUBLESHOOTING

Malfunction	Inspect and Test	Corrective Action
<p>1. Failure to feed</p>	<p>1. Sluggish action</p> <p>2. Check to see if the mainspring buffer is dragging</p> <p>3. Check Magazine</p> <ul style="list-style-type: none"> a. Proper installation b. Dirt/debris c. Damage <p>4. Rifle short cycles</p> <p>5. Bolt carrier assembly binds</p> <p>6. Weak/broken mainspring</p>	<p>Clean and lubricate or (if cold) remove excess lubrication</p> <p>Replace the buffer if the head diameter is over 1.850 in. Replace the buffer if showing excessive/uneven wear</p> <ul style="list-style-type: none"> a. Reinstall magazine into the receiver b. Clean magazine c. Replace magazine <p>Hold rifle more firmly in the shoulder</p> <p>Please contact tech support</p> <p>Replace mainspring</p>
<p>2. Failure to chamber</p>	<p>1. Check cartridge for damage</p> <p>2. Check for dirty chamber</p> <p>3. Check for faulty mainspring</p> <p>4. Check for bent receiver</p>	<p>Remove damaged round</p> <p>Clear and clean chamber</p> <p>Replace mainspring</p> <p>Please contact Tech Support</p>
<p>3. Failure to cock</p>	<p>1. Check bolt carrier for proper assembly, worn or missing parts</p>	<ul style="list-style-type: none"> a. Replace worn or damaged parts b. Reassemble correctly

Malfunction	Inspect and Test	Corrective Action
4. Failure to lock or unlock	1. Check for obstruction between firing pin and bolt 2. Check for excessive dirt or debris in locking area 4. Check bolt spring for damage and proper installation 5. Check for broken or burred bolt latch or bolt latch spring	Disassemble and clean Clean chamber and barrel extension Replace or reinstall bolt spring Please contact Tech Support
5. Failure to fire	1. Faulty ammunition 2. Verify bolt carrier is fully in battery 3. Check for improper installation of firing pin 4. Check for broken or improper installation of trigger components 5. Check for obstruction of the firing pin or trigger	Replace ammunition Manually cycle carrier (do not force carrier closed) Assemble properly Have a Barrett Certified Armorer replace or reinstall trigger components Remove obstruction or debris
6. Failure to extract	1. Check for broken or missing extractor 2. Ensure extractor is moving freely in slot 3. Check for dirty chamber	Have a Barrett Certified Armorer replace extractor Have a Barrett Certified Armorer remove, clean and lubricate extractor, plunger, and spring Clean chamber

Malfunction	Inspect and Test	Corrective Action
7. Failure to eject	Check for proper movement of ejector	Have a Barrett Certified Armorer remove, clean, lubricate or replace ejector and/or spring as needed
8. Very hard recoil	1. Check for faulty/hot ammunition 2. Check for damaged or missing mainspring/buffer 3. Check for loose, missing, damaged/clogged muzzle brake	Replace or cool ammunition Replace/install mainspring or buffer as needed Please contact Tech Support

